



MASSEY FERGUSON

HESSTON



LB2200 SERIES

LARGE SQUARE BALER

**BIG BALES.
BIGGER PROFIT.**



LB2200 SERIES

**OVER 45 YEARS OF
BIG BALER INNOVATION.**

AT HESSTON®, WE HELP HAY PROFESSIONALS PRODUCE THE HIGHEST-QUALITY, HIGHEST-NUTRIENT, HIGHEST-VALUE HAY POSSIBLE. FOR OVER 75 YEARS, WE'VE DELIVERED ON THAT PROMISE. THE LB2200 SERIES LARGE SQUARE BALER IS OUR MOST RELIABLE, MOST PRODUCTIVE BALER EVER.



4 GET MORE DONE



6 BIG BALER. BIGGER GAINS.



8 MORE TIME IN THE FIELD



11 SPECIFICATIONS

Get More Done.....	4
Big Baler. Bigger Gains.....	6
More Time in the Field	8
Technical Specifications.....	11

GET MORE DONE.

THE REIGNING HEAVYWEIGHT IN EXTRA DENSITY

The Hesston by Massey Ferguson® LB2234XD 3x4 Extra Density large square baler delivers more bale density than standard density models, with a longer bale chamber to boot. Major features include:

» **LARGER FLYWHEEL AND SHEAR BOLT**

The flywheel on the LB2234XD is more than 90% heavier than other balers. Its width and diameter create a heavier bale while operating smoothly at a normal load in most conditions.

» **HIGH-CAPACITY GEARBOX AND MOUNTINGS**

Designed to handle heavy loads, the gearbox features large input and output shafts, large gears, heavy castings, beefy crank arms, double clamp bolts, and strong connecting rods that are similar to our 4x4 baler, including the same size bearings.

» **LARGER HYDRAULIC TENSION CYLINDERS**

At 4.5 inches, these cylinders allow for higher bale weight and density at lower operating pressures, resulting in heavier bales and fewer bales in the field. They're also fitted with heavy pivots to improve tension capacity.

» **OPTIFORM EXTENDED BALE CHAMBER**

Our bale chamber design assures better, denser square-shouldered bales.





- » **The LB2200 Series** actively pulls crop from the pickup and positively feeds it into the pre-compression chamber, maximizing capacity.
- » **The ProCut™ rotary cutter** forces crop material through stationary knives (optional). Plus, packer tines behind the rotor help guarantee even feeding into the pre-compression chamber for consistent bale shape.
- » **To help deliver rock-solid, well-formed bales and uniform density**, the LB2234XD feature the OptiForm™ bale chamber that is 16 inches in length, longer than the standard chamber.
- » **Tandem axles** are offered on all LB2200 Series models for improved flotation and increased field speed. The rear axle automatically steers to reduce field scalping and can be locked while loading. A single bogie suspension system offers more ground clearance and fewer parts for increased reliability.
- » **Optional larger width tires** provide greater flotation and reduced ground pressure.
- » **Optional automatic lubrication system** keeps the key drive chains oiled. The timing and duration of this system can be conveniently controlled through the Datatronic™ 5 monitor.

BIG BALER. BIGGER GAINS.

Every aspect of the LB2200 Series was designed to ensure productivity and reliability. The entire design starts and ends with the goal of maximizing your ROI.

HYDRAULICS

All Hesston® LB2200 Series models feature on-board hydraulics for easier hookup and elimination of variables introduced by tractor hydraulic systems that can affect baler performance.

GEARBOX

All models feature a model-specific, high-capacity double reduction gearbox.

FLYWHEEL

The flywheel slip clutch features five discs for drive protection.

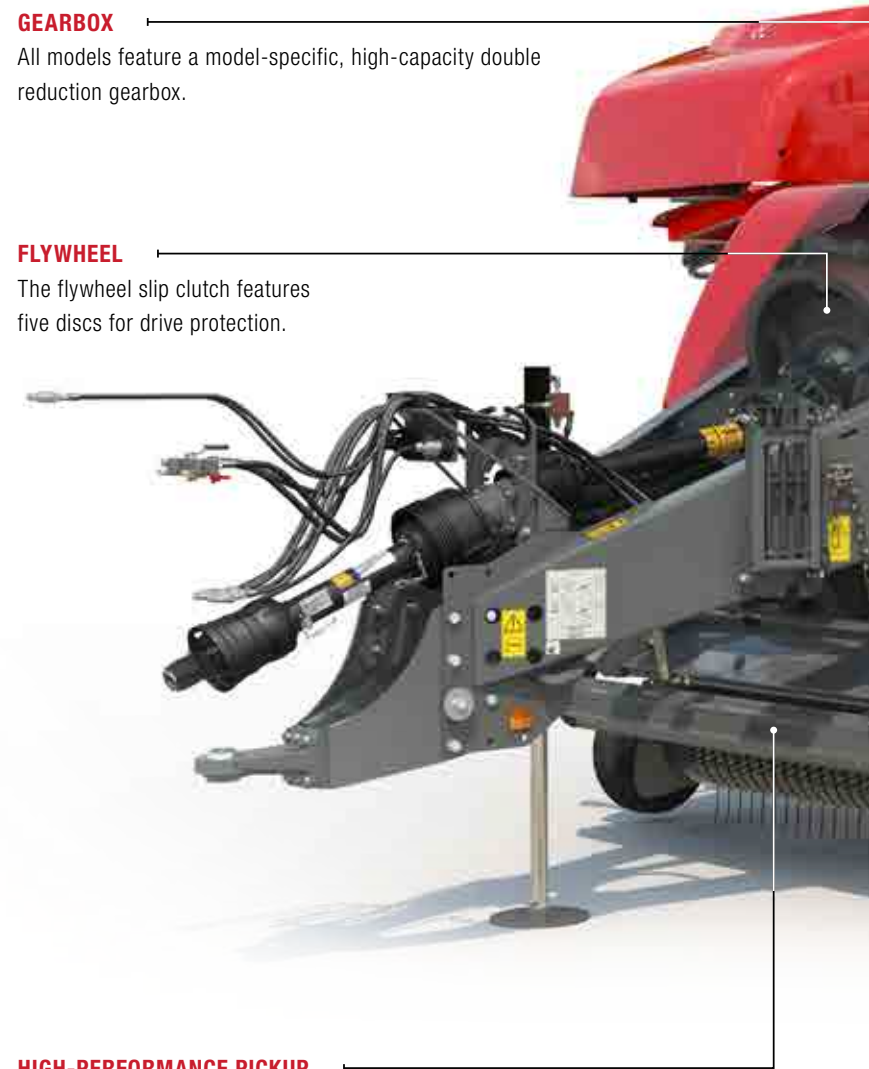

HIGH-PERFORMANCE PICKUP

A five-tine bar pickup reel and light weight poly wrappers enable faster ground speeds and smoother operation.

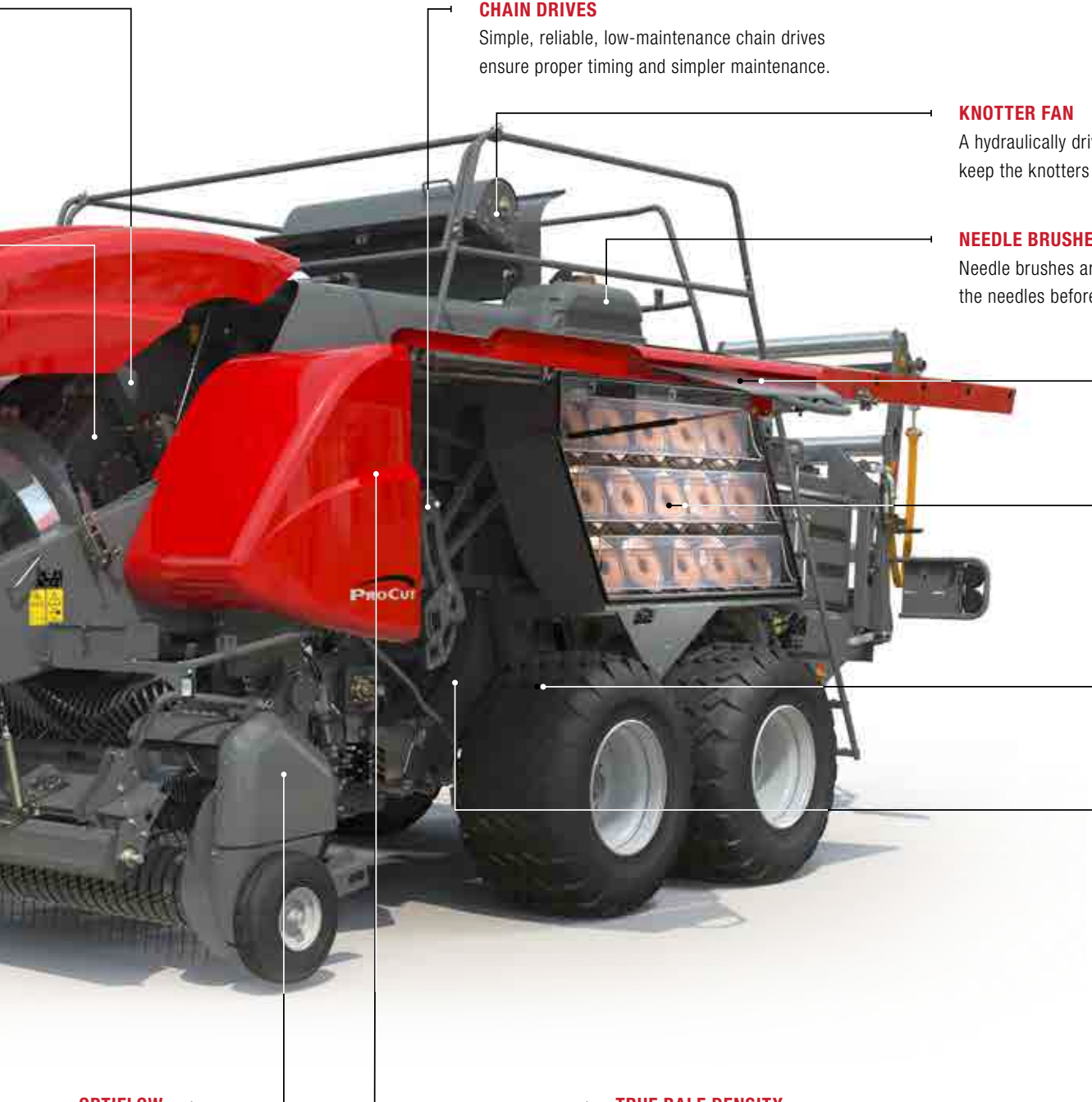

CHAIN DRIVES

Simple, reliable, low-maintenance chain drives ensure proper timing and simpler maintenance.

KNOTTER FAN

A hydraulically driven, transverse-impeller knotter fan helps keep the knotters free of debris, even in high residue crops.

NEEDLE BRUSHES

Needle brushes are standard on all models to clean the needles before they enter the knotter area.

SIDE PANELS

Side panels seal against twine boxes to reduce trash buildup while a mesh screen over the twine box prevents twine from unspooling.

TWINE BOXES

Twine boxes on all models hold 30 balls of twine at a 30-degree angle for easier loading and increased capacity. Exclusive "Giant Spool" option delivers 30% more capacity than standard twine balls.

SMOOTH HANDLING

Enhanced suspension and taller tire offerings improve ride and handling. Hydraulic or pneumatic brakes available as options.

PRE-COMPRESSION CHAMBER

Creates full-shaped rectangular bales with equal density throughout.

OPTIFLOW

Compression spring OptiFlow™ pickup suspension provides smooth floatation over all types of terrain.

TRUE BALE DENSITY

True bale density is measured through load cells on the plunger connecting rods rather than gearbox deflection, providing operators with right and left driving arrows.



MORE TIME IN THE FIELD.

When it's time to bale, lost time means lost money. That's why LB2200 Series balers were designed for minimal servicing and quick and easy maintenance. Sealed bearings mean fewer service points and an eight-hour service interval. An increased number of tapered roller bearings contributes to longer wear life. Even if something does go wrong or a shear bolt breaks, Hesston LB2200 Series balers will not need to have their timing adjusted.

MORE BALES **PER HOUR.**

No matter the baler or the bale size, it's capacity and productivity that gets the job done. Hesston LB2200 Series large square balers have greater capacity than all competitive balers on the market. Consider a few of the other advantages that the Hesston LB2200 Series balers have over the competition:

- **Flywheel weight on the LB2234XD model** delivers high plunger inertia and capacity.
- **High gearbox speeds** on all models translate into higher capacity and better performance.
- **A low-profile, five-bar pickup** retains more nutrient-rich leaves.
- **Standard roller windguard** allows for great pickup contact in residue and silage crops.
- **The solid windguard** provides crop control in all wind conditions and helps to compress the crop mat before it enters the pre-compression chamber.
- **Upper and lower centering augers** feed crop material to the pre-compression chamber for fast baling without sacrificing the Hesston reputation for solid, square-shouldered bales.

AUTOMATIC KNOTTER LUBRICATION The knotters are constantly lubricated by an oil-based autolube system that can be filled from ground level to reduce maintenance time. The lubrication cycle is fully automatic with frequency controlled by the Datatronic 5 terminal.

QUICK AND EASY SERVICE ACCESS One-piece side shields, supported by gas struts, allow for easy access to the twine box and drive systems. The shields seal when closed to reduce crop buildup. Tall and narrow twine box design helps with access to important baler components.

MULTIPLE SERVICE LIGHTS Six LED service lamps plus three switch-controlled work lamps give the operator light when working at night by illuminating access ladders, twine boxes, service areas and knotter assemblies. There's even a work light under the baler, should it be needed.

OPTIONAL HAYBOSS PRESERVATIVE SYSTEM The bale chamber frame is already equipped with mounting points for the AGCO® HayBoss® 700 Hay Preservative System, which includes a 110-gallon tank, in-cab monitor and automatic applicator.

OPTIONAL BALE WEIGHT KIT With our bale scale mounted on the roller chute, you'll get accurate bale weights in the field. And bale weight can be recorded on the bale ID tag, using our HayBoss 700 tagging system.

MFCONNECT® Knowledge is power. Remotely monitor baler functions for enhanced visibility into efficiency and track results for future analysis and improved productivity.

SELECTABLE BALE EJECTOR The bale ejector allows the operator to clear the bale chamber at the end of the field or the end of the day. The selectable bale ejector is particularly valuable when baling high-moisture crops or ejecting part of the bale if the bale chute needs to be folded up.

OPTIONAL HYDRAULIC TONGUE JACK Save yourself the effort of manually hooking and unhooking the baler. Simply use the tractor hydraulics instead.

PROCUT Cut your crop into finer pieces with ProCut, the Hesston-built rotor cutter option available. With ProCut, the packer is behind a large, aggressive rotor for better crop feeding. With a serrated knife design, you get true precision cutting with a hydraulic drop-down and slide-out knife bed to simplify service and maintenance.





TECHNICAL SPECIFICATIONS

MODEL		LB2234XD
Dimensions and Weight		
Cross section (width x height)	cm	120 x 90
Bale length (maximum)	mm	Up to 2,740
Dimensions and Weight		
Bale size – height	in. (mm)	34.4 (875)
Bale size – width	in. (mm)	47.2 (1,200)
Pickup working width	in. (mm)	89 (2,260)
Suggested PTO HP (no cutter)		180
Ideal for		Commercial & Biomass Operations
Main Drive		
Flywheel diameter	mm	990
Flywheel width	mm	250
Flywheel weight	kg	550
Protection		Slip clutch, overrun clutch and shear bolt
Pick-up		
Overall width—less pick-up wheels	mm	2600
Working width—DIN 11220	mm	2250
Number of tine bars		5 with centre carrier
Number of tines		80 double tines
Drive protection		Slip and overrun clutch
Suspension		Compression spring floatation
Packer Balers		
Packer System		Fork type
Packer tines		6 hardened tines
Drive protection		Multi-plate slip clutch
ProCut Balers		
Rotor diameter	mm	650
Number of cuttingknives		0, 13, 26
Knife protection		Twin hydraulicknife bank protection
Drive protection		Multi-plate slip clutch
Plunger		
Speed	strokes / min	47
Length of stroke	mm	740

MODEL		LB2234XD
Tying Mechanism		
Number / type of knotters		6 double knot
Twine type / capacity		High quality polypropylene / 30 spool storage
Knotter blower		Standard –hydraulically driven transverse impeller fan
Knotter lubrication		Standard –AutoLube automatic lubrication to max 26 points
Selectable Length Bale Ejector		
Number of teeth		10 teeth in 5 rows
Number of selectable rows		3 rows selectable
Operation		Independent hydraulic cylinder operated from cab or rear of the baler
Bale Chute		
Heavy duty roller bale chute		Standard
Bale drop indicator		Standard
Folding system for transport		Independent hydraulic cylinder operated from the cab or rear of the baler
Axles and tyres		
Single axle tyresize	Cross ply	N/A
Single axle tyre ply rating		N/A
Tandem axletyresize	Cross ply	600/50-22.5
Tandem axle tyre ply rating		16 ply
Optional tandem axle tyre	Radial	620/50 R 22.5
Single axle maximum rated speed*	km/h	40
Tandem axle maximum rated speed*	km/h	60
Service Brakes		
Hydraulic braking system		Standard
Controland Monitoring System		
ISOBUS		Standard -ISOBUS 11783 Compatible Implement
Implement Terminal		FieldStar 5 Terminal, touchscreen, full colour 23cm (9"), video compatible
Lighting		Premium LED road,work and service lights
Tractor Requirements		
Recommended PTO power –Packer	Hp / kW	200 / 150
Recommended PTO power –ProCut	Hp / kW	250 / 186
PTO Type		Type III 1 3/4" (44 mm)–20 spline CV shaft
Hydraulic spool valve requirement	min / rec	2 or 3 double acting depending on specification

Every effort has been made to ensure that the information contained in this publication is as accurate and current as possible. However, inaccuracies, errors or omissions may occur and details of the specifications may be changed at any time without notice. Therefore, all specifications should be confirmed with your Massey Ferguson Dealer or Distributor prior to any purchase.



Massey Ferguson is a worldwide brand of AGCO Corporation.
Hesston is a brand of AGCO. AGCO, Massey Ferguson and Hesston are trademarks of AGCO.
All rights reserved. | HS23B001NA



MASSEY FERGUSON

HESSTON