

MF TRIDENT SERIES

MF 9695 | 370 HP



MASSEY FERGUSON



**TRIDENT**

INTRODUCING THE MASSEY FERGUSON **TRIDENT™ SERIES COMBINES.**

Harvesters that will increase daily productivity in your field.

Since Massey Ferguson introduced the first self-propelled combine in 1938, it has been committed to improving the farmer's harvesting performance. Every year, Massey Ferguson works to offer the most advanced and productive technology available. But this time - we have to admit - we've gone one better.

This is the new generation of Massey Ferguson combines. The Trident™ Series goes beyond any other machine you know.

We designed this series of combines with a single mission in mind: to increase capacity and reduce complexity so you can produce more every day. We believe the bold new thinking behind these machines will take harvesting to a new level - for years to come.





Reliability

With more than 70 years' experience in developing and producing combines, Massey Ferguson has created a lasting legacy in the agricultural equipment industry. Throughout our history, we have always recognised and placed great value in the hard work and practical knowledge of farmers around the world. That's why listening to their needs and developing our combines to meet those demands in a productive way are our top priorities.

We believe it's a union like no other, and we strive to strengthen it with every new combine we produce.

“Beauty in engineering is that which is simple, which has no superfluous parts and which serves its purpose exactly”.

Harry Ferguson



CAPACITY WITHOUT COMPLEXITY

New systems designed for less downtime, maintenance and effort.

With the Trident™ family of combines you'll put more clean, whole grain in the hopper with less downtime, maintenance and effort. Going back to basics, but also introducing new technologies. With many elements of the new line completely redesigned.

Our Trident™ processing system promotes significantly more separation while increasing grain quality. The innovative multi-stage cleaning system features directional flow separation, all in 5.10m² of total area for the MF 9695. The unique V-Cool™ cooling system operates at full efficiency resulting in a revolutionary line of combines that meets your needs with the strength and reliability of Massey Ferguson.



Model	Engine	Nominal HP(kW)	Max HP(kW)	Reserve HP(kW)	Hoper(L)	Perfect Decision
MF 9695	8,4 L	350 (255)	370 (271)	380 (279)	10.570	<p>The ingeniously simple design of the Trident™ Series provides efficiency and productivity in high performance machines for medium to large producers.</p> <p>Our Trident™ Processor and innovative stratified cleaning system enable high capacity harvesting without complexity.</p> <p>More power combined with greater efficiency means the new Trident™ harvests more acres with less fuel while maintaining the power and torque reserve to tackle the most diverse and extreme conditions.</p>

MORE COMFORT AND PRODUCTIVITY

Harvesting work is hard and arduous, but with the new ComforTech II™ cab, making harvesting easier. The operator position is ergonomic and intuitive, developed for convenience and comfort in the Trident™ Series, leaving every control at the operator's fingertips. The 3.4m³ cab is quieter and more spacious than ever. We've increased insulation, with lower noise levels. All to make you more productive on your long days of harvesting.

VISIBILITY

The ComforTech II™ cab provides you a wide field of vision. With a 5.7m² of glass surface offering the best view of the field, platforms and side mirrors. In addition, the glass reduces glare and heat gain inside the cab. The rear view mirrors are electronically adjustable with "breakaway return", and the large rear window allows a clear view of the grain hopper.





WORK MORE EASILY

Almost everything in the cab is adjustable to increase efficiency to perform tasks.

Ergonomically developed, the high-back seat with air suspension can be adjusted according to your weight and height. You can control the seat angle and depth, as well as the lumbar support. The armrests and their controls move along with the seat adjustments and suspension. The C2100 terminal is strategically located and has an adjustable support for easy operator access.

The steering column and leather-covered steering wheel, feature dual tilt and telescopic height. To maintain air quality, the large-volume filter cleans all air entering the cabin. The air circulates through 11 outlets that provide even distribution and defog the windows.

MAIN CONSOLE AND MULTIFUNCTION LEVER

It's all at your fingertips. The console allows you to control functions such as platform engagement and height adjustments, reel speed, auxiliary drive engagement and all other platform commands. The multi-function lever hydrostatically controls the forward and reverse of the combine, as well as the main functions of the harvesting operation, such as hitching and operating the discharge pipe.

ADJUSTABLE STEERING COLUMN

The narrow design of the column improves visibility during harvesting. The leather steering wheel, the wide footrests and the double tilt with telescopic steering column height all contribute to your comfort.

TRIDENT™ SERIES: **INTELLIGENCE IN THE FIELD**

Monitor and control daily tasks

Previously the success of a harvest was related only to hard work. Today, in addition to that, we have smarter ways of working. That means using the most advanced technology available to maximize yields and increase your financial investment. The technology built into our Trident™ Series provides all of that.

FIELDSTAR II

Fieldstar is the productivity mapping system that monitors the harvest, stores productivity data and machine operational parameters. Using modern sensors and GPS technology, Fieldstar II records machine performance and maps the productivity of the harvest to know the existing variability and help in decision making under the modern concepts of precision agriculture. All this to maximize the outcome of your crop.





MORE PROCESSING POWER

Increased performance with improved fuel economy

Our new processing system - Trident™, was developed to increase grain processing capacity without sacrificing product quality. It features a 360° gentle threshing system that unites intelligence and strength. Here's how:

Each new feature and the new systems, working together, increase performance, reduce power consumption and improve fuel economy.

HOW IT STARTS

We increased the long size of the mouthpiece by 163mm and introduced a new system of transmission. This allows the use of a larger platform (flex or corn - up to 24 rows) and provides 55% more power availability for our feed belt. The result is a higher, more uniform and smoother crop flow.

MF 9695 30 ft / 35 ft (Draper) 16 líneas

DIVIDE AND CONQUER

New rotor feed system now features segmented feeder and adjustment of the gap between the feeder and the bottom of the trough feeder. In addition, the bottom of the feeder housing has a multi-zone flow control, which provides greater rotor feed control by dividing the crop into three parts. This reduces blockages, increases performance and threshing capacity, while keeping power consumption stable, even with large crop volumes.

THE LARGEST ROTOR **ON THE MARKET**



In the harvesting stage, it is important to control the flow of material for correct processing. For this purpose, the new Trident™ series rotor has four spiral rows of segmented, overlapping and removable threshing elements. For higher quality, two rows of narrow and wide interchangeable plates are placed in the separation area. All this coupled with the largest axial rotor in the industry allows for the best threshing capacity (high inertia) and separation with less power requirement.

MF 9695

70 cm

3,56m.

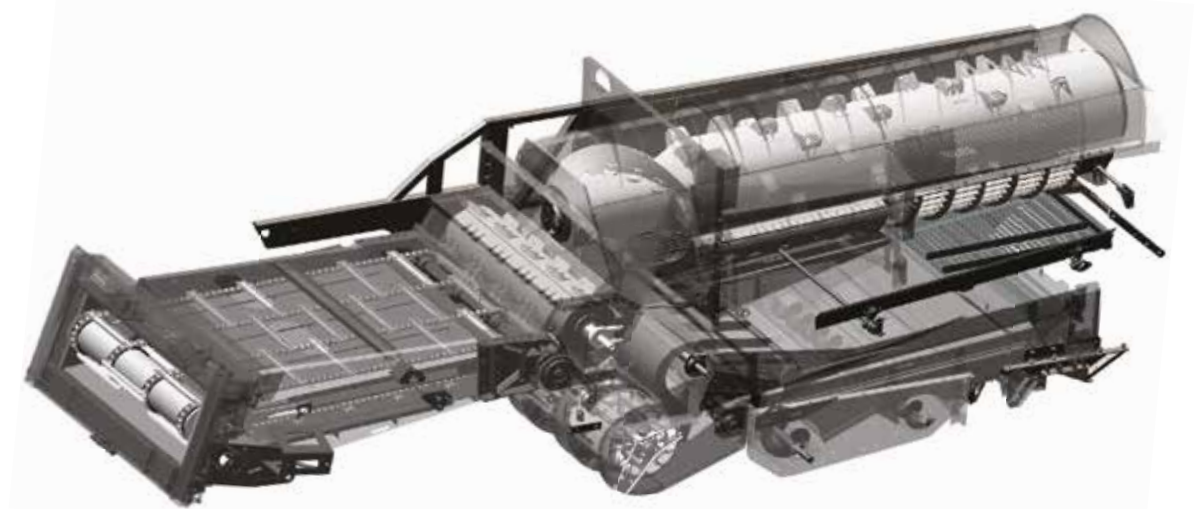

SUSPENSION CONCAVE: **PROTECTION AGAINST OVERLOADS**

This is another Massey Ferguson innovation. The Trident™ processing system concaves are assembled on an H-shaped frame, and this, in turn, is supported by a system of springs that function as a suspension, promoting uniform distribution of the crop, absorbing impacts, reducing accumulation and protecting the concaves from damage during heavy processing.

CROP ADJUSTMENT: **OPERATIONAL EASE**

The innovations don't stop here... Each harvester is equipped with 12 segmented concave sections, facilitating their replacement according to the need to adapt to the crop being threshed. They come in fine, coarse or round bar wire. Thus, you can completely adapt your machine, effortlessly and with extreme practicality and speed.

CLEANING **SYSTEM**

All combines on the market use air to clean the grain, but none like the Trident™ Series performance.

- The Trident™ Series incorporates an innovative multi-stage cleaning system that uses compressed air to clean.
- In the first stage of the process, the 460mm diameter **Max Flow™** fan blows directed air through the top of the screen box. At this point the removal of the dust and any material other than grain that is falling through the concave and rotor screens.
- Additional airflow provides more cleanliness of the sieves. Here, the compressed air is forced over multiple zones, from the back to the front so that the lighter material is carried out of the machine.
- In addition, with the rotor positioned directly above the feeder tray, the need for auger conveyors was eliminated. The new top directed airflow cleaning is performed over the entire length of the processor and still acts on any debris separated at the rear of the rotor.

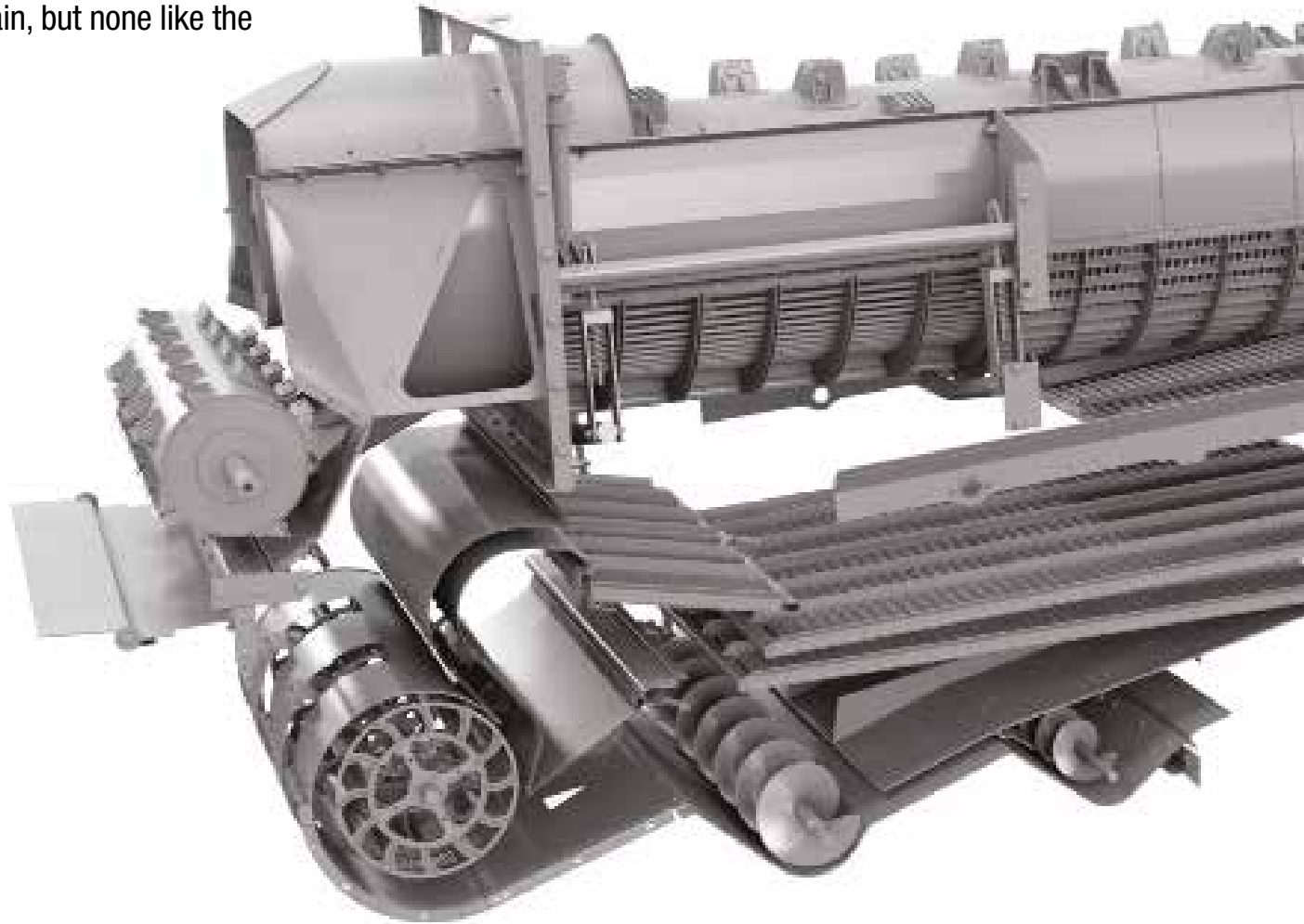

STORAGE AND UNLOADING SYSTEM

The MF 9695 has a grain tank volumes of 10570 10,570 litres with 88 L/s discharge rate. The less time you spend unloading, the more time you spend harvesting.

Model	Discharge Rate
MF 9695	88 litres/sec

NEW DISCHARGE PIPE UP TO 7.6 M LONG

The Dynaflex Draper 35 ft and 40 ft platforms, in conjunction with the combine, provide much more operational comfort and less maneuvering for grain unloading, whether moving or stationary.

Model	Platform	Auger Size
MF 9695	30 ft / 35 ft	6,8 m (20 ft)

QUICK FILL AND **EMPTYING OF THE GRAIN TANK**

Massey Ferguson has always been a pioneer when it comes to fast hopper filling, and the Trident™ Series proves this.

One of the reasons for this is the clean grain elevator and auger. When it comes to unloading, our high volume option offers better performance. Unloading on the move or at the static end of the field. That's because it uses fewer augers, aligned with each other for unrivaled unloading, allowing a direct, in-line flow of grain with more speed and less damage.

SIMPLICITY IN **THE DRIVES**

With all the innovation and technology available, this harvester remains simplistic.

The new Trident™ series of harvesters was radically thought and reshaped to feature high-tech transmissions for direct and more efficient power transfer in all components. The drive system was reduced to 14 main belts and 4 chains for the Trident™ Series. In addition, power demands on the belts, such as slippage, wear and potential failures, were minimized and reduced. As a result, you have a harvester that is much more reliable, easier to maintain and cheaper to operate.



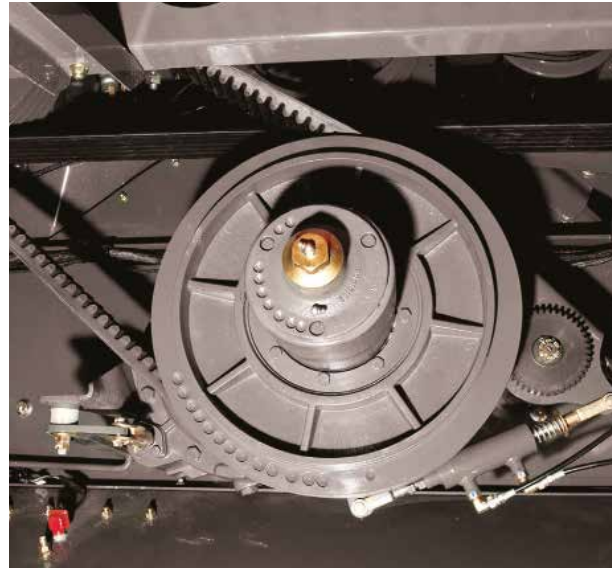

IN-LINE AND **DIRECT ROTOR DRIVE**

Another novelty is the motor aligned with the rotor. This allows us to maintain the direct transmission of power from the motor to the rotor through a high-capacity rotation variator system and without transfer boxes, fewer moving parts, less downtime. The platform, the feeder, cleaning fan and elevators are in a single system - but they are all connected to a single gearbox, which keeps the gear ratio always in sync, efficient and direct, ensuring power transfer for each assembly.

CHOOSE THE IDEAL SPEED **FOR YOUR HARVEST OR TRANSPORT**

The four-speed transmission offers more speed options in the field for transport. Regardless of the type of terrain, the ideal harvesting speed can be selected.

MORE EFFICIENT AND SIMPLER DRIVE SYSTEM

By means of a hydraulically controlled coupling through a two-stage clutch, the power is directly routed through a high-capacity pulley and belt system for heavy-duty application. Resulting in gain in transmission capacity with very low fuel usage.

ROTOR INVERSION AND MUCH MORE

The rotor drive uses a variable speed drive system and a gearbox with two rotating belts. It allows you to set the working speed of your rotor for any crop or condition. This system, in addition to providing a wide range of speeds, offers the lowest speeds in the category and, in addition, it performs the inversion of the rotor speed. On rotation of the rotor, the feeder channel, the augers and the elevators. And all this is done from the cabin, simply by pressing a button.

- High: 460-1,235 rpm
- Low: 264-709 rpm

VARIABLE SPEED CLEANING FAN

The variable rotation drive control system of the cleaning fan offers complete control over the speed of air blown into the screens. From the cab, you can control this speed, adjusting rotation and flow without changing pulleys or belts. Speeds vary from 916 to 1,336 rpm, favouring the most diverse crops.

TRANSMISSION OF THE CLEAN GRAIN CONVEYING SYSTEM

The system is driven from the left side of the machine directly from the transfer box. Rotation and power are transmitted to the clean grain cross auger and then to the elevator. Simple and straightforward, the system guarantees maximum output at the highest yields for your crop.



MAXIMUM PERFORMANCE AND **SUPERIOR PERFORMANCE**

AGCO Power's 7-cylinder, Trident™ Series engines are exceptional, Manufactured in our own AGCO POWER factory. AGCO POWER engines have been assembled for over 65 years and are respected around the world for their durability, reliability, unmatched torque and fuel economy.



BUILT FOR **MORE POWER**

The MF 9695 is powered by AGCO POWER 8.4 litre, 7-cylinder in-line engines. The engine offers greater power density to deliver more power. The proof is in the numbers, with a rated rotation at 2,100 rpm and maximum power capacity at 1,950 rpm, ensuring maximum performance. The 2,100 rpm grain unloading power reserve system delivers the maximum power capacity at 1,950 rpm, ensuring maximum performance.

MF 9695 350 hp (rated) 370 hp (max) 380 hp (reserve)

INCREASED POWER AVAILABILITY **REDUCES EMISSIONS AND FUEL ECONOMY**

High-pressure common rail direct fuel injection (CRDI) and an efficient air-cooling system help ensure emissions control. At the same time, they ensure the availability of power and torque while maintaining excellent fuel economy.

As an added benefit, the turbo offers immediate response to changes in loading conditions, such as unloading during harvesting.

SELF-CONTROLLED **FUEL ECONOMY**

Our Electronic Engine Management **4 (eeM4)** is the most advanced fuel injection system developed by AGCO. It monitors engine performance and is capable of up to **100 adjustments per second** so that fuel delivery rate and timing are in constant sync. Simple and easy, it helps your engine respond more quickly to power demands, reduces exhaust emissions and improves fuel economy.

EXCLUSIVE V-COOL™ SYSTEM **LEAVES OTHERS EATING DUST**

It's no secret that the harvesting environment is demanding on the engine and its cooling system, always pushing it to its maximum capacity. We know that the daily task of cleaning the cooling system and air filter is time-consuming and tiring for you and your equipment.

That's why Massey Ferguson introduces another innovation to prevent overheating, the constant need for maintenance and to keep the cooling system running smoothly and the engine at its peak performance and technologically advanced that you're going to wonder how no one thought of that before.

OPTIMIZING **FLOW EFFICIENCY**

On competitive combines, the engine, air conditioning, hydraulics and intercooler radiators are superimposed. On the Trident™ Series, these are arranged in a unique V-format, which allows unrestricted airflow to flow through each radiator. Because the engine air is removed from this area of the V-Cool™, the air filters have longer life and better performance.

VARIABLE **FAN SPEED**

Another innovation of the Trident Series is in the cooling fan drive system for the engine. The fan is driven hydraulically, adjusting the speed automatically to keep the engine temperature in an optimal working range. The fan runs continuously, and only accelerates when necessary. This improves performance.

The power not used by the motor fan may be available to control other areas, such as the Trident™ processing. This reduces fuel consumption in low-mass or low ambient temperature harvesting conditions.



CONTINUOUS CLEANING WITHOUT **STOPPING THE MACHINE**

How many times do you clean the cooling system system during harvest? Once? Twice a day? The Trident™ Series does this automatically for you. The “V-Cool” cleaning fan is reversible and, as you work, it cleans the system’s intake grill. This functions by blowing air into the radiators automatically every 15 minutes, depending on the temperature. As the dust accumulates on the screen, the system reverses the rotation and ejects the residues that are clogging the screen. With this ability to control the ideal temperature the engine and air filter life increases saving time.

DISTRIBUTION OF RADIATORS **IN A “V” SHAPE**

This unique “V” configuration allows the cooled airflow to pass through all cooling units only once. This eliminates the heat and debris that are trapped between the radiators, which are superimposed one in front of the other, more efficiently, unlike traditional models.

AUTO REVERSE **FUNCTION**

As you work, the variable speed fan is reversed and blows the chaff residue off the inlet screen, eliminating the need for rotating brushes.

BETTER TERRAIN HANDLING WITH LESS VIBRATION

It all starts at the front. The platform maximizes the performance of your combine. With more processing capacity available on Trident™ Series combines, requiring a platform that meets the demands of the machine and provides feed capacity. That's why Massey Ferguson offers a full range of platforms.

With the same level of capacity, control and operational efficiency of our combines in the Draper DynaFlex MF 9250 flexible platforms. Unique because they offer all the flexibility of a flexible platform with smooth, seamless material flow control.

SMARTRAC™: KEEPING THE PLATFORM IN THE CUT

It is always a challenge to keep the rigs in the correct harvesting position when operating on undulating terrain. But the Smartrac system, unique to Massey Ferguson, automatically transforms assumptions and doubts into operational certainties.

Developed and built for Massey Ferguson axial harvesters connecting directly, without adapters or complex transmissions.

DynaFlex swallows the crop with every pass. The cutting width reaches up to 12.2 m. The flexible cutterbar is controlled from the cab, along with our Smartrac™ lateral tilt, providing up to 203 mm of vertical movement for harvesting in uneven areas. With the capability to pick up very low pods and lying plants as easily as standing ones. With the ability to control the longitudinal tilt forward/reverse in a variation of up to 12 degrees for the best cutting angle.

BAT FLIP-OVER WINDLASS

The factory reel version for this platform is the Bat flip-over. The direction of rotation of the fingers provided by the reel reduces crop tangles, allowing you to start harvesting earlier and continue later, even in difficult conditions.



Independent tilt arms, located every 76 cm along the length of the platform extension, are hydraulically controlled and range from 0 to 3,000 psi for precise and smooth control. Yet, with a single touch, the platform can be converted into a rigid unit for wheat and barley crops.

DynaFlex MF 9250, equipped with a SHC (Schumacher) cutting system, epicyclic and cardan shaft driven gearbox, delivers up to 400% more torque than conventional cutters. This means smooth bar performance with high cutting capacity. Cut and collected, the material is driven through a reinforced rubber belt to the central area where a feeding auger takes the material to the funnel.

Model	Size (m)	Drive	Weight (kg)
MF 9695	30 (9,10) / 35 (10.6)		

Double Box 2,208 / 2,771

Engine Performance		MF 9695	
Engine Type			AGCO Power
Displacement			8.4 L / Turbo Intercooler
no. of Cylinders			6 in line
Rated Power @ 2,100 rpm			350 hp (255 kW)
Maximum Power @ 1,950 rpm			370 hp (271 kW)
Power Reserve @ 1,900 rpm			380 hp (279 kW)
Fuel tank capacity - Litres			643
Cooling System			V-Cool
Transmission			
Transmission			Hydrostatic with 4 gears with 4 speeds
Adjustable Rear Axle	Meters		3.15 (not adjustable)
Double Front Wheels:			800/65 R32
Rear Wheels			23.1 X 26
Hydraulic System			
Hydraulic pump	Degrees		Piston / variable displacement
Hydraulic reservoir capacity	Litres		85,2
Cab and Controls			
Seat			Deluxe, high back, air suspension
Inner volume	m ³		3,4
Controls			LD Console / Monitor C2100
Working Lights			12 lights
Power Supply System			
Feeding Mat			3 Chains / bolted crossbars
Power Inverter	Litre/min		Electro-hydraulic
Feeder channel width	mm		1121
Height and tilt control			Standard (Electro-hydraulic)
Stone Trap	Max kgs		Standard
Threshing and Separation			
System			Trident Axial Flow
Types of concave			Thin or thick wire and round rod
Concave overload protection			Spring suspension system (12.7 mm course)
Concave / Threshing area	m ²		1,2
Separation area	m ²		1.92
Rotor type			Segmented units and stripping plates
Rotor diameter	mm		700
Rotor length	mm		3556
Drive type			Variable belt and pulley / 2 speeds
Speeds	rpm		Low scale: 264-709 / High scale: 460-1235
Rotor inverter	mm		Electro-hydraulic / ring and pinion gear

		MF 9695	
Cleaning System			
Pre-cleaning area	m ²		0,6
Upper Screen Area	m ²		2,44
Lower Sieve Area	m ²		2,06
Total area	m ²		5,1
Shale Shaker Drive			Manual
Cleaning fan type and diameter	mm		Transversal / 457.2
Fan rotation			916 at 1,336 rpm
Hopper			
Hopper opening			Mechanical
Hopper Capacity	Litres		10570
Discharge pipe diameter	mm		280
Discharge rate	Litres/Sec		88
Discharge pipe length	m		6,8
Discharge pipe height	m		4,2
Waste distribution (optional)			
Rotor output	Degrees		Straw spreader; 4 speeds
Exit of the sieves	Litres		Chaff spreader
Precision Agriculture			
Productivity Monitor			Fieldstar II
Autopilot			Auto-Guide™ 3000 (STD)
Cutting Platform			
Draper	ft/m		30 ft (9.14) or 35 ft
Electro - Hydraulic Coupling			Unique - all functions
Windlass Rotation Control			Proportional (Standard)
Dimensions and Weights			
Maximum height	m		4,7 (800/65 R32)
Transport Height	m		3,75 (800/65 R32)
Outer tyre width	m		4,1 (800/65 R32)
Inner tyre width	m		2,06 (800/65 R32)
Pipe Height	m		-
Pipe Nozzle Height	m		4,45 (800/65 R32)
Opening	m		0,53 (800/65 R32)
Length with Platform	m		13,24 (800/65 R32)
Weight with Platform	kg		19000 with 30ft (800/65 R32)
Weight without Platform	kg		16383 (800/65 R32)



www.masseyferguson.com/en_za

<https://www.facebook.com/MasseyFergusonSA>

https://twitter.com/MF_RSA

<https://www.instagram.com/masseyfergusonsouthafrica/>

https://www.youtube.com/channel/UCR_x855-b18-iKtSGZx7Vg



MASSEY FERGUSON® is a worldwide brand of AGCO.
© AGCO Corporation | A-A-17317 | English



BORN TO **FARM**