

MF ACTIVA S

MF 7345 & MF 7347

5 OR 6 STRAW WALKERS | 260-306 HP



MASSEY FERGUSON





MF ACTIVA S

FLEXIBILITY IS THE KEY

CLEAN RESULTS



08

THRESHING & SEPARATION

Built To Meet The Demands..... 4
 Choose Your Table..... 6
 Threshing & Separation 8
 Grain Tank & Shaker Shoe..... 10
 Clean Results..... 12
 Introducing the Proline Cab..... 14
 Made For Power & Efficiency..... 22
 Paralevel System 24
 Parts & Service 28
 Specifications 32

PARTS & SERVICE



28

14

INTRODUCING THE PROLINE CAB

22

MADE FOR POWER & EFFICIENCY

MF ACTIVA S

BUILT TO MEET THE DEMANDS OF THE TOUGHEST HARVESTS

Designed to offer choice for farmers, the Massey Ferguson Activa S combine range has features for performance and practicality. The operator has been given higher levels of comfort in this class while being offered simple straightforward choices of specification.

Those with medium to large farms often have a variety of crops to combine and each machine needs to offer the best selection of settings to get the output required with a good clean sample. Surveys show that the operators of these machines need practical solutions to do this and value simplicity and comfort.

Model	Max power (hp/kW)	No. of straw walkers	Grain capacity (litres)
MF ACTIVA S 7345	260/192	5	8600
MF ACTIVA S 7345 MCS	260/192	5	8600
MF ACTIVA S 7345 MCS PL	260/192	5	8600
MF ACTIVA S 7347	306/225*	6	8600
MF ACTIVA S 7347 MCS	306/225*	6	8600
MF ACTIVA S 7347 MCS PL	306/225*	6	8600

*With power boost
PL – ParaLevel

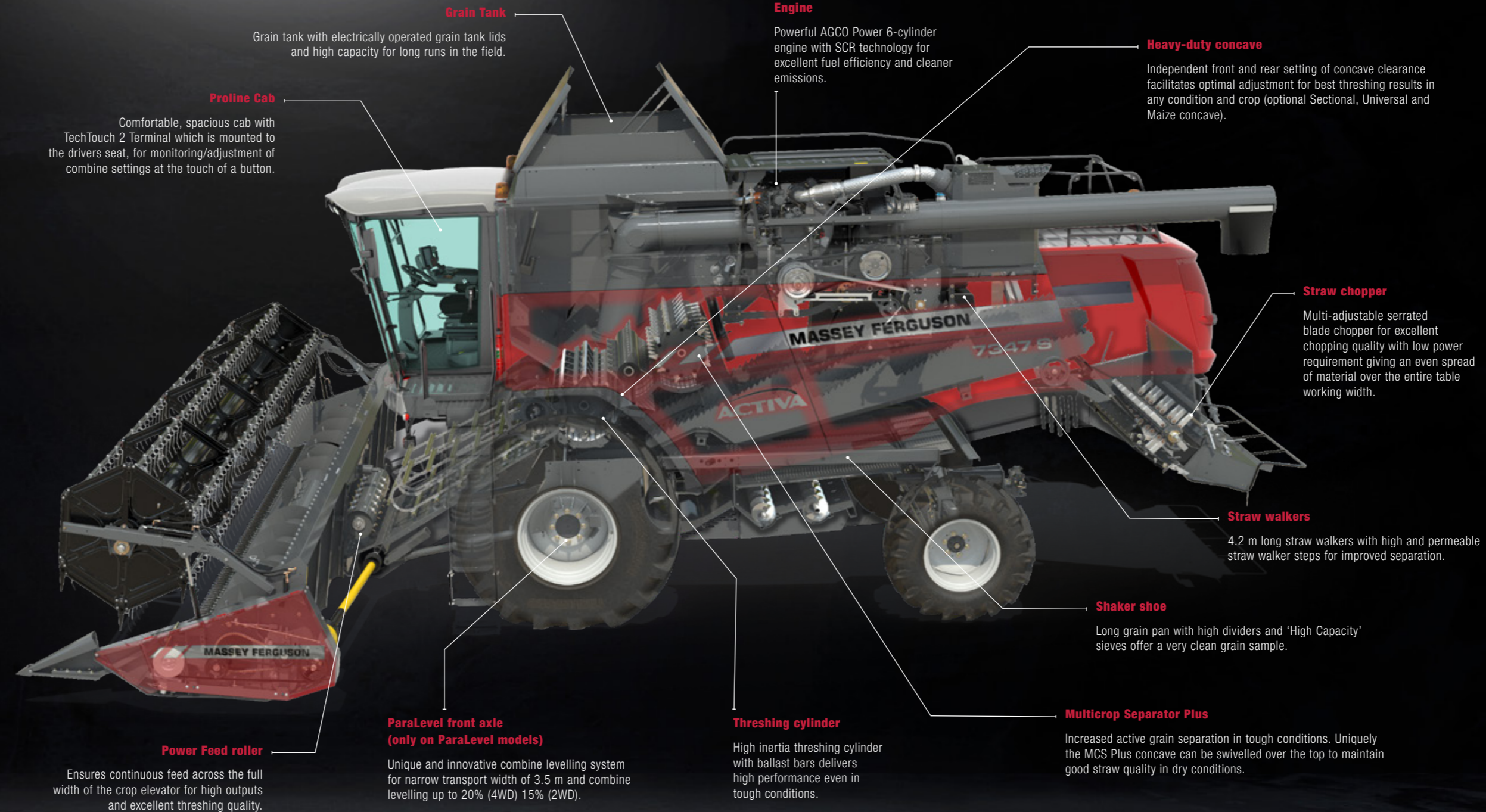

VIRTUAL REALITY



Use your smart phone to step inside the MF ACTIVA S



◀ STEP 1
Use a QR code reader app. Download it for free from iTunes or the Android Play store.



◀ STEP 2
Open the app and scan this QR code...



◀ STEP 3
...and step inside your Massey Ferguson combine.

Live the eXperience in 2D, moving your smartphone around in all directions or using your fingers.



◀ STEP 4
Live the full VR 3D Experience by clicking on the dedicated icon and use in combination with a pair of VR glasses.

CHOOSE YOUR TABLE

START WELL, FINISH WELL.

Your header is critical to how well your combine performs. With a lifetime of experience, Massey Ferguson offers you a choice of its premium PowerFlow table or high capacity FreeFlow tables. Both have features for productivity like Automatic Reel speed and advanced table height control.

Combined multicoupler is standard for quick table dismount.

The Power Feed Roller (MCS Version only) at the front of the main crop elevator gives a consistent crop flow from the table into the main crop elevator. It can be reversed simply and effectively from the cab.



Full width auger fingers on the FreeFlow table increase auger throughput, ensuring positive and fast feed into the main crop elevator.

The Schumacher knife is the best performing knife in the business at 1,254 cuts a minute. Self-cleaning and consistently sharp, this keeps the crop moving in tough conditions.

FREEFLOW
UP TO 7.6 M

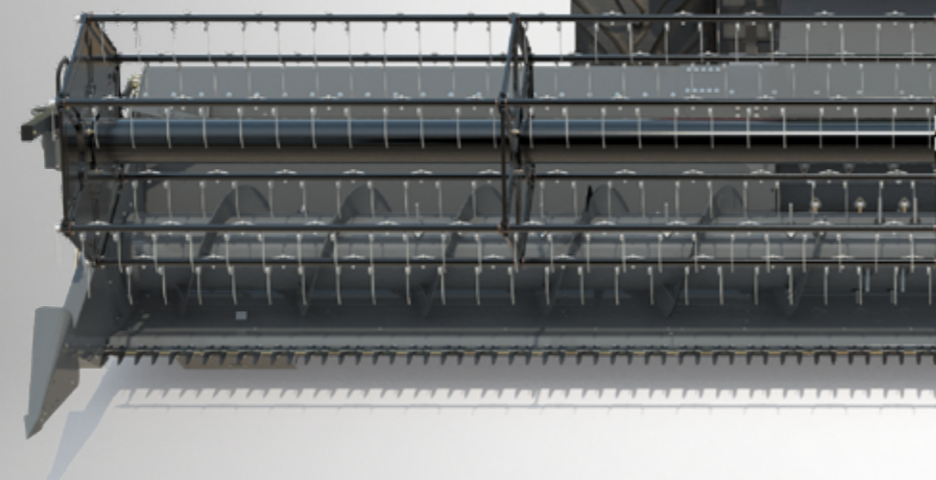

POWERFLOW
UP TO 6.8 M

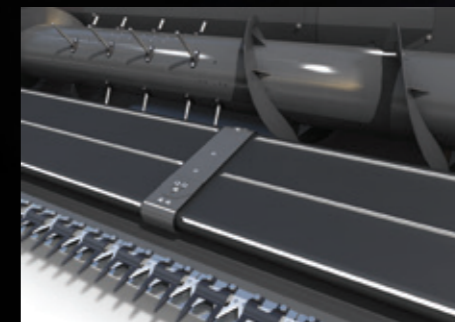
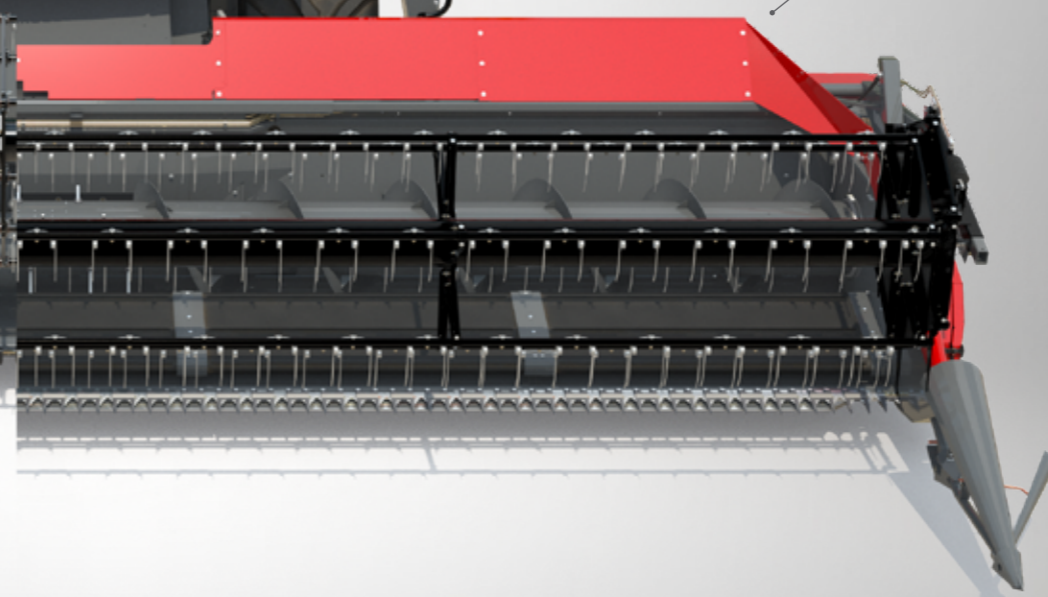

The knife is a massive 1.14 m from the table auger, so vision and performance are optimum. The rugged PowerFlow belts power the crop away from the knife and into the main crop elevator at a consistent speed. The belts also deflect stones rather than taking them into the machine where they might cause damage.



TerraControl II provides a mix of automatic functions for the standard table-levelling (FreeFlow or PowerFlow), ground-following system (Field pressure) and headland management – all the metrics are controlled from the operator's multifunction lever. Small changes in height requirement can be made quickly and easily creating an even feed in changing conditions. The automatic reel speed function takes tasks away from the operator so they can focus on getting the best from the machine.



The optional rape auger for the PowerFlow table increases the flow of tall crops into the elevator thereby increasing the output considerably. Two electrical side knives complete the rapeseed kit.

THRESHING & SEPARATION

THE FLEXIBLE HEART OF THE COMBINE. EQUIPPED WITH A ROBUST, HIGH-INERTIA CYLINDER AND A HEAVY-DUTY CONCAVE, THESE MACHINES CAN HANDLE CROPS EASILY.

The threshing drum has added weight in the form of ballast bars which increases the inertia in the cylinder as the rasp bars thresh the heads. This reduces load on the drives, power requirement and fuel consumption.

Two versions of the combine are available:

- ▶ Concave with the ABC module (an extension to the separation area of the concave and is adjustable in three positions)
- ▶ Concave with the ABC module, Power Feed Roller and MCS (Multicrop Separator)

OPTIMISE THRESHING QUALITY

The concave has differentiated wire spacing, the rear section of the concave has half as many wires as the front section. This principle provides the optimum balance between high threshing capacity and good grain flow through the concave. The concave, front and rear, can be set from the cab independently in order to optimise the threshing quality.

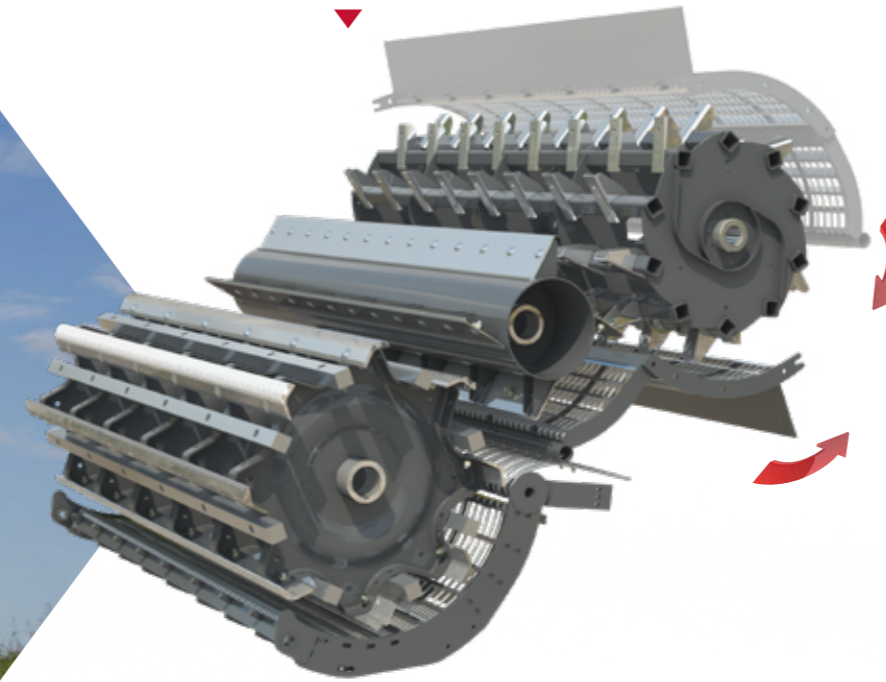

▲ TWO SYSTEMS IN ONE

The Multicrop Separator (MCS) provides a massive separation area to remove as much of grain as possible before it reaches the walkers

The MCS has one unique feature that sets it apart from the rest, the ability to rotate the concave up over the top of the rotary separator when it is not required. The MCS concave is moved electrically, requiring no tools. This makes it possible to optimise machine performance in dry conditions reducing the load on the shaker shoes and considerably improving the straw quality.

A MULTITUDE OF APPLICATIONS ▶

A full maize kit can be fitted including a maize concave. For this application the chopper speed reduction kit comes as standard with the grain version.

To increase versatility and save time Massey Ferguson can offer an optional Sectional concave which is designed to harvest a multitude of crops. The conversion time when moving from small grain to large seeded crops such as Soya, Maize and Sunflower can be completed in minutes rather than hours.

A sectional concave with removable elements can be fitted if required.



A special Rice cylinder / concave version can be ordered with unique peg and tooth design, specifically for separation in tough conditions.

Additional components are also fitted which have extra wearing capability. This includes the grain augers, elevators and the MCS teeth. These specifications coupled with self-lubricating tracks and tables specific with hard wear components provide a versatile machine for rice as well as grain and maize.



GRAIN TANK & SHAKER SHOE

More clean grain in the tank brings higher returns. Efficient, but gentle threshing, followed by the well-proven separation and cleaning system results in the highest quality sample in the tank. Special attention to the shaker shoe with the use of high capacity cleaning sieves gives you the best quality sample from the field. An optional yield monitor and moisture sensor – the Ceres 8000i with integral SD card reader – can be fitted.

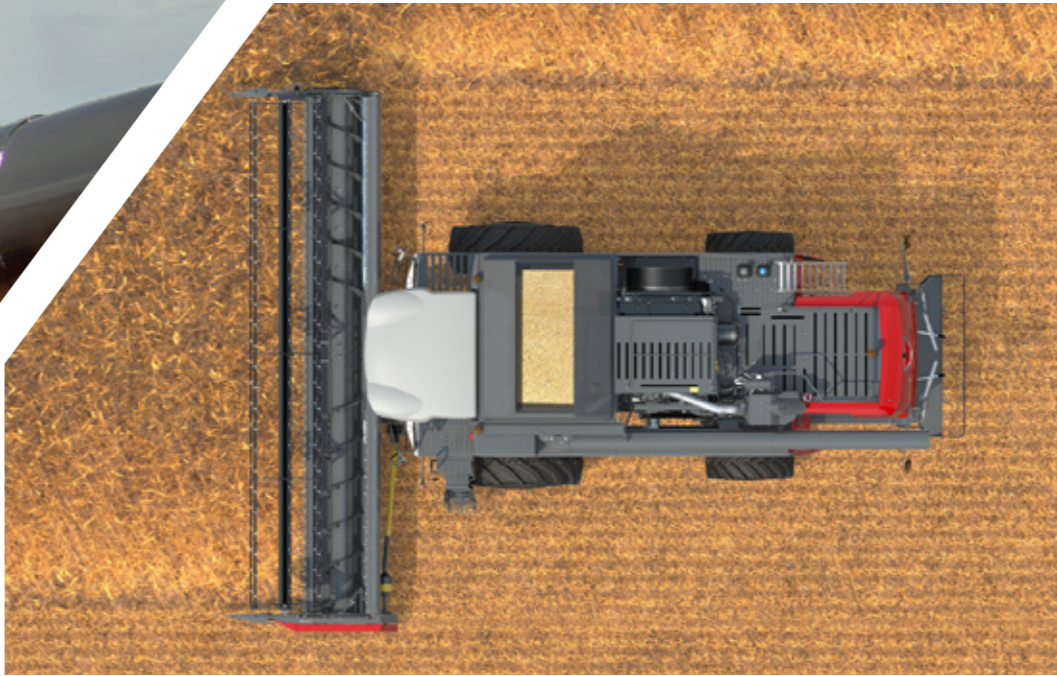

THE GRAIN TANKS HAVE A HIGH CAPACITY OF 8,600 LITRES, WHILE THE UNLOADING RATE OF 105 L/SEC IS FAST FOR QUICK UNLOADING. THE TURRET AUGER CAN COPE WITH THE HIGHEST OF TRAILERS IN THE FIELD OR ON THE ROAD.

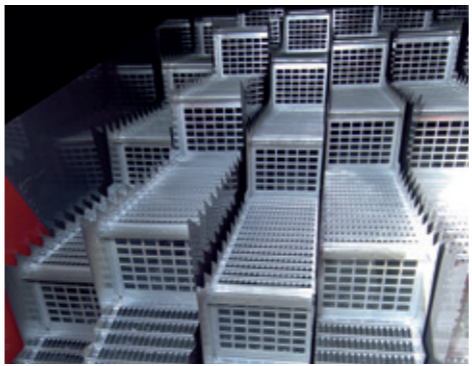

STRAW WALKERS

The long straw walkers feature four steps with 'active walls'. The 21 cm high, vertical sections of the walker steps are made up of permeable grids. These are the highest for any conventional combine. The front steps of the straw walkers are reinforced for maize.



SIEVE PROFILE

The sieve profile is the key to shaker shoe performance. The high performance sieves are specially designed with vertical tags which improve the sample and allow you to open the sieves wider for greater throughput. The practical design also allows one person to remove and clean the sieves easily between crops.

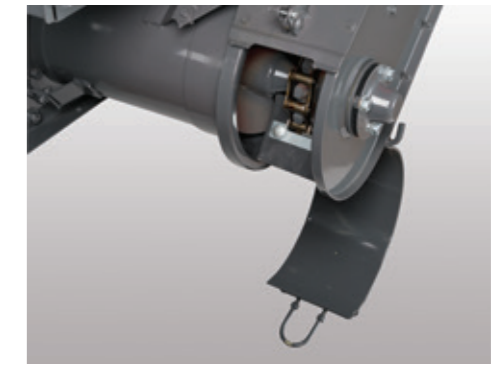

GOOD GRAIN AND RETURN AUGER

The good grain and return auger are reinforced where there is a direction change for long life and durability. This is particularly good for maize harvest where the wear from the crop is accelerated or in other conditions of high wear. For economy the elevator bottoms can be unbolted individually and replaced easily and less expensively.

CLEAN RESULTS

THE STRAW CHOPPER IS SPECIFICALLY DESIGNED TO PROVIDE CHOPPING AND SPREADING PERFORMANCE SUITABLE FOR FARMERS USING REDUCED TILLAGE OPERATIONS.

The knives are serrated to give a clean chop and reduce the power requirement. The fully adjustable stationary knives and straw chopper hood ensure complete control over the quality and spread of the chopped straw. Electrical deflectors for the straw chopper are available as an option. This allows the straw to be directed away from the uncut crop if required.



ADJUSTABLE DIMPLE PLATE

An adjustable dimple plate is standard to make sure straw is chopped consistently.

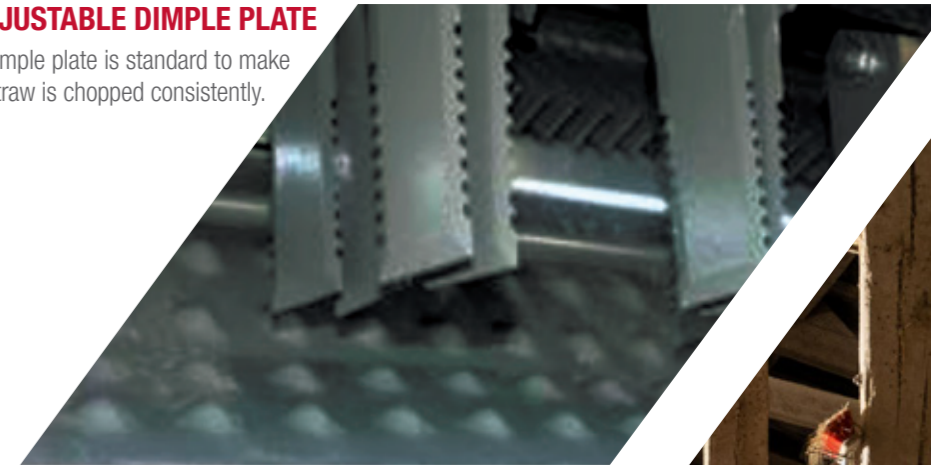

CHAFF SPREADER

A twin rotor multi adjustable chaff spreader is available as an option.

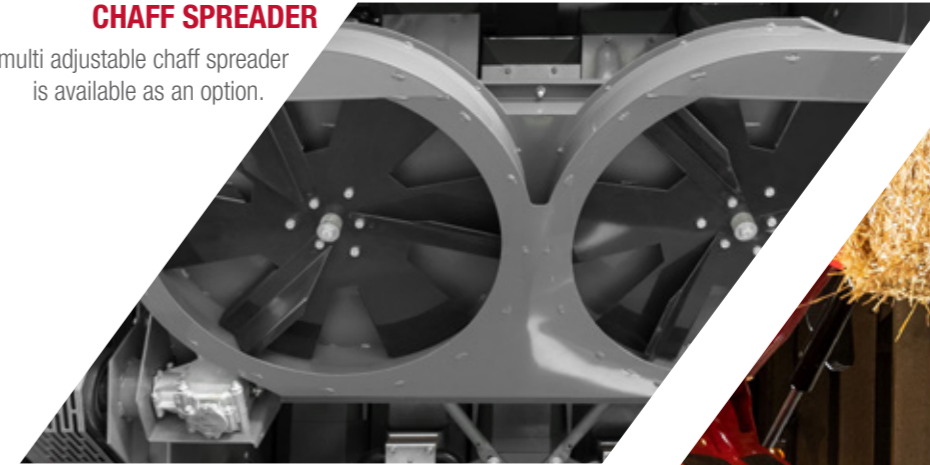

THRESHING SYSTEM

For those that require straw, the threshing system is gentle and leaves the straw in perfect condition for baling feed and bedding straw or producing products for power generation.



INTRODUCING THE PROLINE CAB

An excellent cab environment is the key to getting the best performance from the machine and operator. Excellent visibility with ergonomically placed controls makes the workload easier and more productive. Intuitive menus on the TechTouch 2 terminal provide information at a moment's notice and active warning systems protect your investment.

“ Designed for you to get the best from your machine day or night. ”



The cab comes with a host of features you would expect in an operator environment of this quality.

- ▶ Fully automatic air conditioning including heating
- ▶ Air suspension seat
- ▶ Electrically adjustable heated mirrors
- ▶ Instructor seat with integral cooler box option
- ▶ Excellent sound insulation means you work in quiet comfort
- ▶ Safe and easy-to-use cab steps

View your stubble scenery



Enhanced visibility with the mirrors



The TechTouch 2 Terminal right at hand



Clear view of the unloader auger when in operation



Main controls from the operator's eye



YOUR CONTROL CENTRE

Fundamental elements of good cab design include space, comfort and visibility. The Proline cab offers all of these, ensuring complete operator comfort at all times. Visibility is excellent with a panoramic view for the operator including header, stubble, unloader and the rear with large electrically adjustable mirrors.

TIME TO HARVEST

Night working package includes H9 high intensity lights for all-round excellent visibility late into the evening.



6 adjustable H9 working lights above the cab

4 fixed H7 lights and two H9 working lights

Optional working light package with 6 row finders, stubbles and rear lights

GET THE BEST FROM YOUR MACHINE WITH OPERATOR-FRIENDLY CONTROLS



TechTouch 2 Terminal

Perfectly in view and reach is the TechTouch 2 terminal which provides all the relevant performance information for setting the combine. The touch screen controls with clear definition are easy to use and adjust.

Power grip lever

The new control interface for the operator falls naturally to hand - the PowerGrip Multifunction lever sits on top of the armrest which houses all the switches for the commonly used controls. The armrest can be raised and moved forward to suit the driver using two levers on the right hand side of the console.

Keypad

The membrane keypad is located directly on the right side of the armrest and is used to operate the principle combine functions. The soft, raised keys lead directly to the individual menus on the TechTouch 2 terminal.

- Reel fore/aft
- Reel lift/lower
- Automatic header control engagement
- Automatic stop
- Cutting header up/down
- Cutting header level left/right
- Unloading tube open/close/Auto

Unloading engagement

- Drum speed setting
- Front concave clearance
- Rear concave clearance

- Fan speed setting
- Upper sieves setting*
- Lower sieves setting*
- Straw chopper deflector L/R*
- Grain tank cover open/close
- Vertical knives engagement*
- Road mode

Reel speed setting

Propulsion activation

Engine speed setting

- Park brake engagement
- 4WD engagement*
- Cutting header engagement
- Thresher engagement

Power Grip armrest

The right-hand armrest is the central operating unit where the key engagement switches sit with the throttle control. Designed with a large soft pad to cushion the arm during a long day allowing for maximum comfort. As the propulsion lever does not need to slide it makes operation far less tiring than conventional set-ups.

*optional

OPERATION AND CONTROL FROM YOUR FINGERTIPS

Simple to read and use

- ▶ The easy-to-read colour touch screen can be adjusted for each operator, with choices for what should be displayed.
- ▶ Clear uncluttered display makes the job of interpreting the information very easy – warnings are shown clearly as a priority.
- ▶ Automated crop settings – up to 10 variations of crop settings can be added within the menu on the TechTouch 2 terminal, which when selected will alter the combine automatically.



The new TechTouch 2 terminal is the control centre for all key performance operations, it has a touch screen, and you can use the unique safety navigator to display the screen you require.



◀ Working Screen – As soon as the combine is ready to harvest, the Combine Information Screen is displayed. With colour indicators for table height, performance and return volumes, it's easy to monitor with a quick glance. When in operation, audible and visual alarms are displayed to protect the combine.



◀ Dashboard – At the bottom of the screen there is a permanent dashboard showing forward speed, engine rpm, fuel capacity and the transport gear.

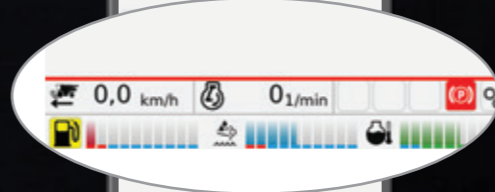

◀ Automatic Setting – Automatic setting can be actioned through various menus for a wide variety of crops, which saves time and energy. For each crop there are further combinations (for example when the conditions are damp or dry) that can be stored.

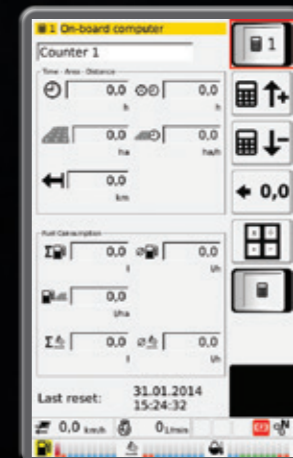

◀ Trip counters – The TechTouch 2 terminal also contains a series of logs that record hours, hectares, fuel and tank fills in various modes. The operator can reset these at any time or save versions if he wants to return to a field and continue the logs. This is useful for field records and those that combine for others.

MADE FOR POWER & EFFICIENCY

“ We think it will make a significant difference to you and future generations. ”



We can promise you that your AGCO POWER Stage V engines use SCR (Selective Catalytic Reduction) and SC (Soot Catalyst) as the main exhaust after-treatment technology. It's better for the environment and delivers some of the lowest running costs in the business.

Consistent, reliable harvesting performance in all conditions is ensured thanks to the engine delivering a long, flat torque curve specifically designed for constant power delivery under load. Combined with the highly efficient drivelines, this also saves fuel, increasing harvesting efficiency and cutting costs.



**LATEST &
CLEANEST**
engine technology



7.4 L ENGINE
uses DOC + SC + SCR
after-treatment system



LOW NOISE
Running at lower rpm



FUEL SAVING
Very low fuel consumption



**MAINTENANCE-FREE
SYSTEM**

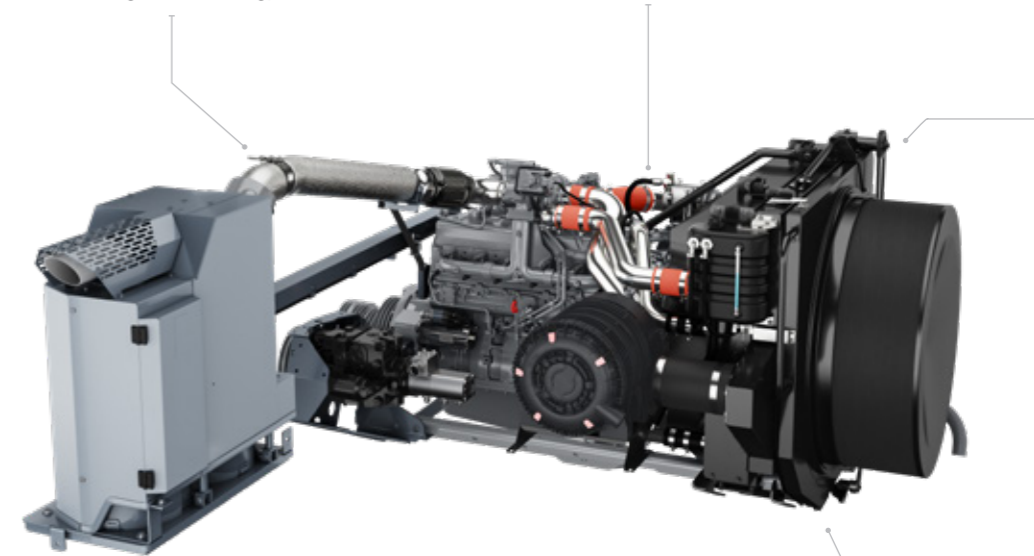

PARALEVEL SYSTEM

ADVANCED SELF-LEVELLING DESIGN OFFERING YOU TOTAL FLEXIBILITY ON INFLEXIBLE TERRAIN



20% (4WD) 15% (2WD)

TRANSPORT WIDTH WITHIN 3.5 M
(800 tyres MF 7345 S MCS PL) (650 tyres MF 7347 S MCS PL)

Simple parallel linkage makes for effortless change of angle in the field. Both the MF 7345 MCS and MF 7347 MCS are available as a ParaLevel version, this patented system offers levelling with the table on slopes up to 20% (4WD). Combine components are generally designed to work on the level. This system maintains that level longer on slopes and therefore keeps the machine working at maximum efficiency for longer - increasing your output.

Part of the package for balance is a standard 4WD system (2WD option), which gives more positive steering control and greater traction in all conditions, and a PWM valve, which provides a smoother leveling system with a better head control, making it a safer place for your operator to work.





MFconnect

FUSE SYNCHRONISED

CONNECTED ANYWHERE. ANY TIME.

GREATER UP-TIME, OPTIMISED MAINTENANCE AND SMARTER SERVICES WITH MF CONNECT.

OWNER, DEALER AND COMBINE ARE 100% CONNECTED!

MF Connect is a fleet monitoring system, that allows customers to keep a close eye on their Massey Ferguson machines.

Viewing machinery operations and equipment operating parameters in virtually real time on their mobile phone, tablet or desktop computer has never been easier.

This enables owners and managers to manage operations more effectively, helping to improve operating efficiency with remote diagnostics, ensuring optimum uptime.



INFORMATION,
WHEREVER AND
WHENEVER YOU
NEED IT

MFcare

FIX YOUR COSTS AND GUARANTEE OPTIMUM PERFORMANCE FOR YOUR MF ACTIVA S WITH MF CARE.

MF Care Service and extended warranty contracts are flexible to suit your payment and operating hours requirements. Regular servicing provides preventive maintenance – picking up any faults before they become a problem, which helps reduce downtime. A full dealer service history using genuine AGCO Parts will also increase the residual value of the machine.

- ▶ Support maximum residual value of your tractor
- ▶ Flexible terms and long-term price packages
- ▶ Available up to 12 months from registration
- ▶ Experienced MF technicians available for on or off-site servicing

	SILVER	GOLD
DETAILS	REGULAR MAINTENANCE CONTRACTS The Service Package includes all prescribed maintenance work on the basis of fixed prices.	REPAIR CONTRACTS Extended warranty contracts which offer security against repair costs (except wear). Tariffs with or without excess available as an option.
MACHINE TYPE	All	All
REGULAR MAINTENANCE*	YES	YES
REPAIR COST	NO	YES
DEDUCTIBLE	NO	Option: €0, €190, €490

*the list price stated by AGCO refers solely to the extended warranty and doesn't include maintenance.

MASSEY FERGUSON OFFERS A COMPREHENSIVE AND EFFICIENT RANGE OF SERVICES

					
6,000 hrs 5 years	3,000 hrs 5 years	50,000 bales 5 years	6,000 hrs 5 years	2,000 hrs 3 years	25,000 bales 3 years

ISOBUS compatible machines only

PARTS & SERVICE

IT'S ALL ABOUT A LIFETIME OF SUPPORT

Buying, owning and maintaining farm machinery can be complex, so having absolute peace of mind that you have great back-up and support is a hugely important consideration. As a Massey Ferguson customer you are assured of personalised, responsive and friendly support from our network of expert dealers who truly understand your business.

There's no cut-off time for Parts and Service because a machine may be out of service. We're available to you throughout your ownership of your Massey Ferguson machine.

We take great pride and responsibility in every machine we sell and we make it our mission to keep your machinery running reliably, every time you turn the key.

“ Easy access to removable grain pan sections helps me get the job done quickly ”



THE MF ACTIVA S HAS BEEN DESIGNED TO PROVIDE FAST, STRAIGHTFORWARD, EASY AND COST-EFFECTIVE ROUTINE MAINTENANCE.

We have combined practicality with style to ensure daily maintenance is speedy, straightforward and simple, taking the stress out of maintaining your combine, getting you to the field earlier for greater productivity and giving you some free time. With a Massey Ferguson MF ACTIVA S combine, time spent in the yard preparing for the day ahead is kept to a minimum.



Easy refuelling - both tanks are located next to each other for easy access



Checking and cleaning the air filter



Easy change from chopping to swathing for bales



Safe and simple access for radiator cleaning



Ladder rail makes inspection easy and safe



One piece panels with lights allow for quick inspection access

MFservices

ALWAYS BY YOUR SIDE TO INCREASE YOUR PROFIT AND EFFICIENCY

WELCOME TO MF SERVICES – EVERYTHING YOU NEED TO SUPPORT THE OPERATION OF YOUR MF ACTIVA S COMBINE.

Accessible and adaptable, MF Services will help you control running costs, budgeting and business planning - ensuring each machine's operating hour is a success and giving you the freedom to focus fully on the core business of farming.

This comprehensive suite of service-related-products makes it easier than ever to own and operate Massey Ferguson farm equipment.

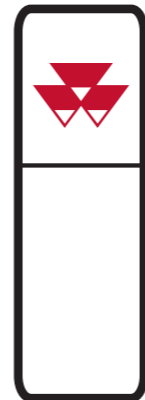

MASSEY FERGUSON DEALER NETWORK

Your MF dealer represents the best farm machines expertise in your area. You can always turn to your dealer and receive the best service from sales, maintenance, repair and spare parts to the purchase of a new piece of equipment.

MORE THAN 4,700 SERVICE & REPAIR POINTS WORLDWIDE

For the above support packages, country terms and conditions apply. Please note all packages may not be available in all markets.

Please check with your local MF Dealer/ Distributor.



MASSEY FERGUSON GENUINE PARTS

REPRESENTS THE BEST GUARANTEE OF SAFEGUARDING THE VALUE OF YOUR NEW MF ACTIVA S OVER TIME, PROTECTING IT FROM UNPLANNED DOWNTIME.

Choose from an extensive range of accessories including lubricants, AdBlue, care kits, cab accessories and much more. All accessories are available for purchase exclusively from your MF dealer.

Using the smartphone app "AGCO Parts Books to go", you can find MF spare parts quickly and easily and order them directly. The app is available for download in the App Store and in the Google Play Store. Your personal access data is available from your MF dealer.

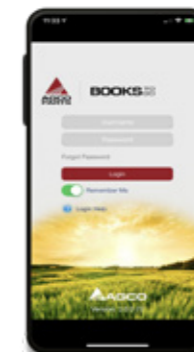

AGCO FINANCE PROVIDES THE PERFECT FINANCING ARRANGEMENT FOR YOUR BUSINESS.

AGCO Finance is the integrated financial services arm of Massey Ferguson offering tailor-made solutions to your own farm, which includes Leasing, Loan facilities, Hire purchase, Full service packages and Contract hire including the financing of MF Care extended warranty contracts.



MASSEY FERGUSON COLLECTION

NOW YOU CAN LOOK AS STYLISH AS YOUR MASSEY FERGUSON.

Looking for a cap to match your MF ACTIVA S... or a stylish and durable



AGCO'S HARVEST PROMISE OUR CONFIDENCE IN SECURING YOUR HARVEST

AGCO's Harvest Promise is our commitment to you that, in the exceptional situation we can't get the parts to you in 48 hours, we will help you through our dealer network or even contribute towards a contractor to step in and harvest your crop until you're up and running again.*

*Terms & conditions apply. Only available in selected markets.

overall to keep working? We have an exclusive range of high quality products to suit you, your farming activity, your family and your lifestyle.

To find out what we have available please login into our online Shop:

Shop.MasseyFerguson.Com

SPECIFICATIONS AS STANDARD

Table and main crop elevator	MF ACTIVA S 7345	MF ACTIVA S 7345 MCS	MF ACTIVA S 7345 MCS PL	MF ACTIVA S 7347	MF ACTIVA S 7347 MCS	MF ACTIVA S 7347 MCS PL
Cutting widths available on FreeFlow (m)	4.80 to 7.60	4.80 to 7.60	4.80 to 7.60	4.80 to 7.60	4.80 to 7.60	4.80 to 7.60
Cutting widths available on PowerFlow (m)	5.50 to 6.80	5.50 to 6.80	5.50 to 6.20	5.50 to 6.80	5.50 to 6.80	5.50 to 6.80
Table and elevator reverser	●	●	●	●	●	●
Automatic reel speed	●	●	●	●	●	●
TerraControl II Automatic Cutting height control	●	●	●	●	●	●
TerraControl II Autolevel table and Field pressure	●	●	●	●	●	●
Power Feed roller	-	●	●	-	●	●
High-inertia cylinder	●	●	●	●	●	●
8 threshing bars + 8 ballast bars	●	●	●	●	●	●
Width / diameter (mm)	1340 / 600	1340 / 600	1340 / 600	1600 / 600	1600 / 600	1600 / 600
Speed range (rev/min)	380 to 1100	380 to 1100	380 to 1100	430 to 1210	430 to 1210	430 to 1210
Concave						
No. of bars	12	12	12	12	12	12
Wrap angle (degrees)	120	120	120	120	120	120
Area (m ²)	0.83	0.83	0.83	0.99	0.99	0.99
ABC concave (degrees)	14	14	14	14	14	14
Multicrop Separator	-	●	●	-	●	●
Width / Diameter (mm)	-	1340 / 600	1340 / 600	-	1600 / 600	1600 / 600
Separator concave						
No. of bars	8	8	8	8	8	8
Area (m ²)	-	0.9	0.9	-	1.07	1.07
Rotating concave system	-	●	●	-	●	●
Straw walkers						
No. / No. of steps	5 / 4	5 / 4	5 / 4	6 / 4	6 / 4	6 / 4
Total separation area (m ²)	6.72	7.62	7.62	7.99	9.06	9.06
Shaker shoe						
Grain pan with high dividers	●	●	●	●	●	●
Top and bottom electrical adjustable sieves	○	○	○	○	○	○
Total area (m ²)	4.67	4.67	4.67	5.58	5.58	5.58
Full width volumetric blade type fan	●	●	●	●	●	●
Fan speed rev/min	350 to 1050	350 to 1050	350 to 1050	350 to 1050	350 to 1050	350 to 1050
Returns to cylinder	●	●	●	●	●	●
Fan speed adjustment, electrical, in cab	●	●	●	●	●	●

KEY

- Standard specification
- Optional
- Not available
- * Depending on market legislation
- ** Low regulation fuel versions available
- † Not available in all countries

Every effort has been made to ensure that the information contained in this publication is as accurate and current as possible. However, inaccuracies, errors or omissions may occur and details of the specifications may be changed at any time without notice. Therefore, all specifications should be confirmed with your Massey Ferguson Dealer or Distributor prior to any purchase.

Grain tank	MF ACTIVA S 7345	MF ACTIVA S 7345 MCS	MF ACTIVA S 7345 MCS PL	MF ACTIVA S 7347	MF ACTIVA S 7347 MCS	MF ACTIVA S 7347 MCS PL
Capacity (litres)	8600	8600	8600	8600	8600	8600
Unloading rate (l/sec)	105	105	105	105	105	105
Auger length (m)	5.0	5.0	5.0	5.0	5.0	5.0
Unloading height (m)	4.5	4.5	4.5	4.5	4.5	4.5
Residue handling						
Straw chopper	●	●	●	●	●	●
No of knives	52	52	52	64	64	64
**Engine						
AGCO Power Selective Catalytic Reduction (SCR)	●	●	●	●	●	●
Capacity (litres)	7.4	7.4	7.4	7.4	7.4	7.4
Power (ISO 14396) hp/kW *with Power Boost	260/192	260/192	260/192	276/203 306*/225	276 / 203 306*/225	276 / 203 306*/225
Fuel tank capacity (litres)	620	620	620	620	620	620
AdBlue® (litres)	80	80	80	80	80	80
Transmission						
Hydrostatic / 4 gears	●	●	●	●	●	●
Tyres						
Front	650/75 R 32	650/75 R 32	650/75 R 32	650/75 R 32	650/75 R 32	650/75 R 32
Rear	460/70 R 24	460/70 R 24	460/70 R 24	460/70 R 24	460/70 R 24	460/70 R 24
Proline Cab						
Heater, air conditioning, electrically controlled view mirrors, air suspended seat, 3D steering column, TechTouch 2 terminal						
Dimensions						
Overall length without table (mm)	9070	9070	9070	9070	9070	9070
Width without table, standard tyres (mm)	3190	3190	3290	3485	3485	3498
Weight (kg)	12800	13100	14500	13300	13600	15100

Options

	MF ACTIVA S 7345	MF ACTIVA S 7345 MCS	MF ACTIVA S 7347	MF ACTIVA S 7347 MCS
Residue handling				
Straw chopper hood with electrical deflectors	○	○	○	○
Chaff spreader	○	○	○	○
Option Tyres				
Front	800/65 R 32	800/65 R 32	800/65 R 32	800/65 R 32
Front	710/75 R 32	710/75 R 32	800/65 R 32	800/65 R 32
Front	900/60 R 32 [†]	900/60 R 32 [†]	900/60 R 32 [†]	900/60R32 [†]
Rear	540/65 R 24	540/65 R 24	540/65 R 24	540/65 R 24
Front below 3.5 m	800/65 R 32	800/65 R 32	650/75 R 32	650/75 R 32
Rear below 3.5 m	540/65 R 24	540/65 R 24	460/70 R 24	460/70 R 24
High performance top sieve for maize	○	○	○	○
Fan speed reduction (270 to 840 rev/min)	○	○	○	○
Accessories				
4WD rear axle multimedia system with navigation, Yieldmeter maize kit, air compressor, pea and bean kit				



8360 - 9070 mm



3190 - 3720 mm

DESIGNED TO OFFER
**CHOICE TO
FARMERS**





www.MasseyFerguson.co.uk

www.facebook.com/masseyfergusonGlobal

[Twitter.com/MF_EAME](https://twitter.com/MF_EAME)

[Instagram.com/MasseyFergusonGlobal](https://www.instagram.com/MasseyFergusonGlobal)

www.YouTube.com/MasseyFergusonGlobal



MASSEY FERGUSON® is a worldwide brand of AGCO.
© AGCO SAS. 2021 | A-A-17324 | English



MASSEY FERGUSON